

Flat Pattern view
SCALE: 1:2

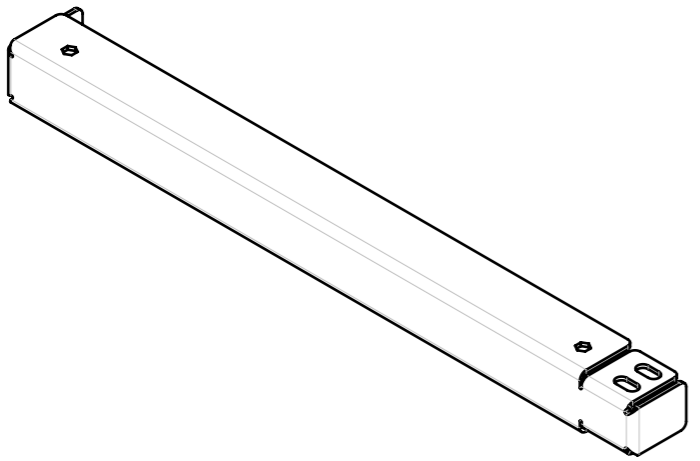
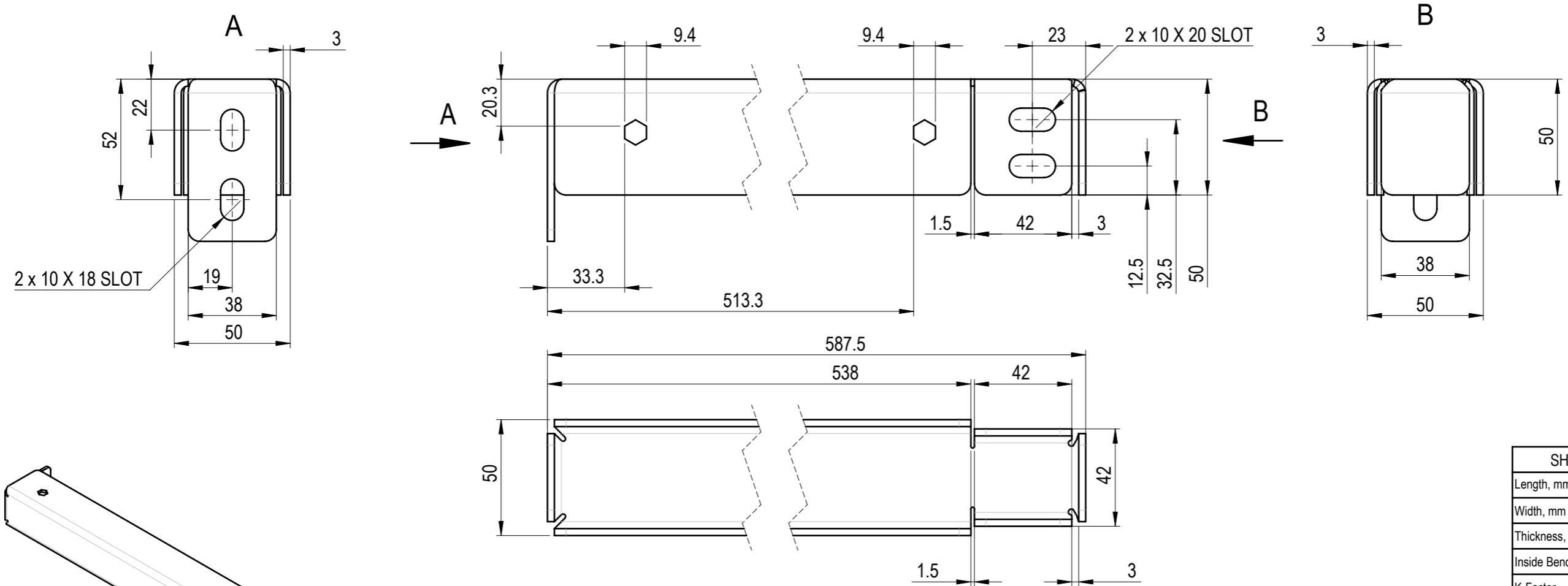
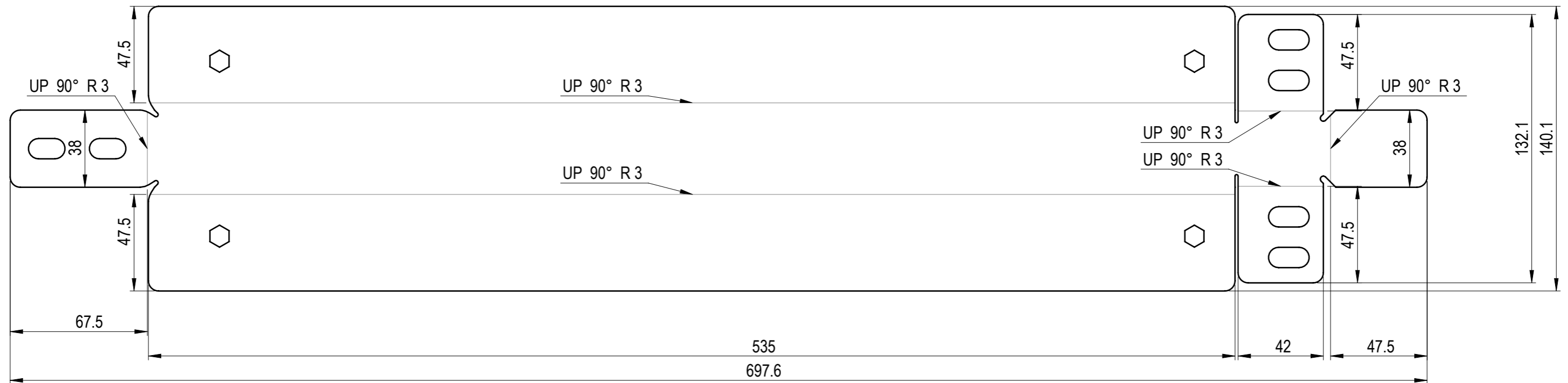

SHEET METAL INFORMATION	
Length, mm	697.6
Width, mm	140.1
Thickness, mm	3
Inside Bend Radius, mm	3
K-Factor	0.5
No. of Bends	6

Other dimensions from .DXF file.

	MATERIAL	DX51D+Z275	WEIGHT	1.956 Kg	DEBURR AND BREAK SHARP EDGES	REVISION	DATE
	SURFACE PROTECTION	HDG + G3.02 EN ISO 12944	MACHINING	ISO 2768 mK	DO NOT SCALE DRAWING		6/4/2025
	NAME	SIGNATURE	PART NO.	105-09100-81		SCALE 1:2	
Designed by	D. Dislers		DESCRIPTION	U-Profile 7		FORMAT A3	
Drawn by	D. Dislers					SHEET 1/1	
Technical ref.							